



Volumetric electronic filler **Fillstar FX**

Fillstar FX series is the GEA Procomac range of aseptic volumetric electronic fillers with magnetic flow meters for any still product, including high acid, low acid, clear, with pulps, fibres, pieces and viscous drinks.

The product is pushed by an overpressure of inert gas, present in the filling tank, through a linear product path, and the filling process is made without contact between the filling nozzle and the bottle. The flow meter determines the quantity of liquid according to the container and closes a membrane valve when the preset quantity is reached. There is no other moving component in contact with the product. Furthermore, a dual speed

design (slow speed mode is used at beginning and end of filling cycle) allows to avoid foaming for very critical products.

Key features of FX fillers are also the internal sterilization by means of steam and the changeover without breaking of sterility for any container with the same neck finish, due to complete bottle "neck handling" system. CIP cups insertion and extraction for closed-loop CIP and SIP are completely automatic.

GEA Procomac is one of the first companies to achieve the 3A international certification for its milk filling machine based on the new "third party verification" procedure.

Fillstar FX: flexible aseptic filling technology

Volumetric electronic aseptic filler for still products: safe, flexible and user friendly

Features

- Volumetric electronic filling head with magnetic flow meter
- Excellent features for aseptic filling of still liquid
- No contact between filling nozzle and the bottle neck
- Automatic CIP cups insertion and extraction for closed-loop CIP (international patent)
- User-friendly touchscreen control panel

Advantages

- Advanced product and container flexibility:
 - clear products or products containing pulps and fibres filling capability;
 - complete neck handling system: fast bottle changeover;
 - self-adapting grippers to treat bottles with different neck diameters available as an option.
- Optimal hygiene
- Fully automatic CIP and SIP cycles

GEA Procomac range of FX volumetric electronic fillers includes:

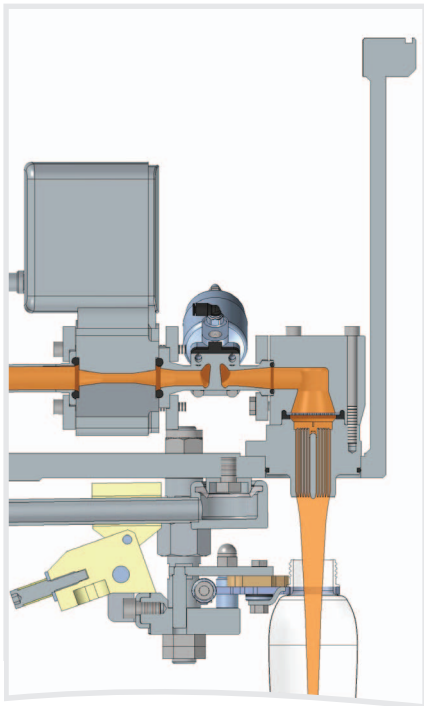

FX filling valve for still clear products

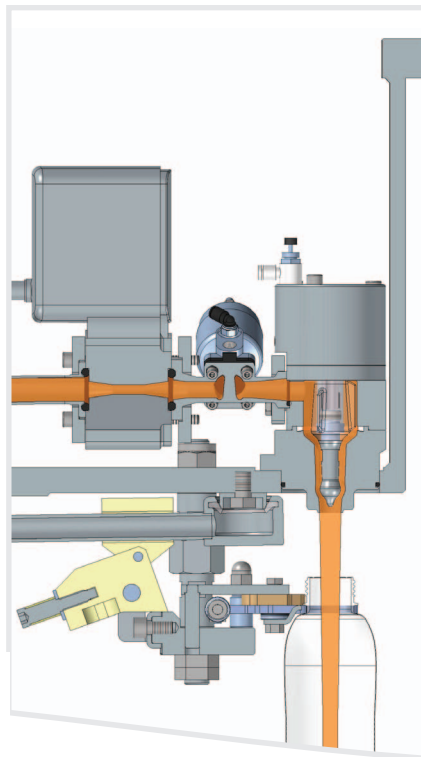

FX P filling valve for still products with and without pulps and fibres with maximum dimensions of 3 mm diameter x 20 mm length

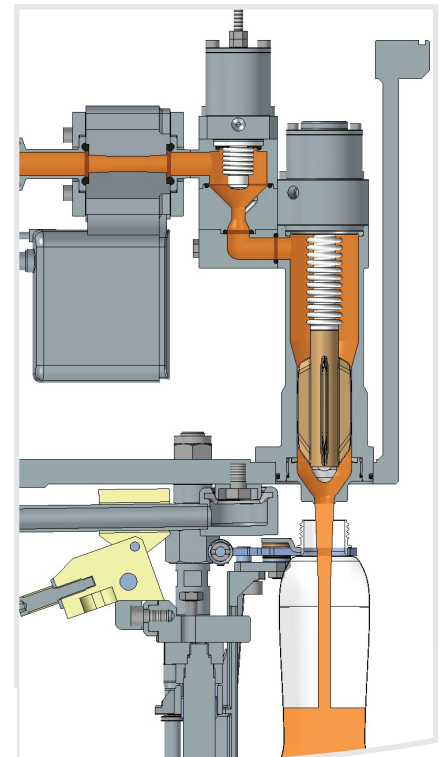

FX C filling valve for still products with and without pulps, fibres, pieces with dimensions up to 5x5x5 mm



GEA Process Engineering

GEA Procomac S.p.A.

Via Fedolfi, 29 - 43038 Sala Baganza (PR) Italy
Tel: +39 0521 839411, Fax: +39 0521 833879
sales.procomac.it@geagroup.com, www.procomac.it