

UPGRADE FOR HYDRAULIC RETAINER ON STERILIZERS (“SPIN” Version)

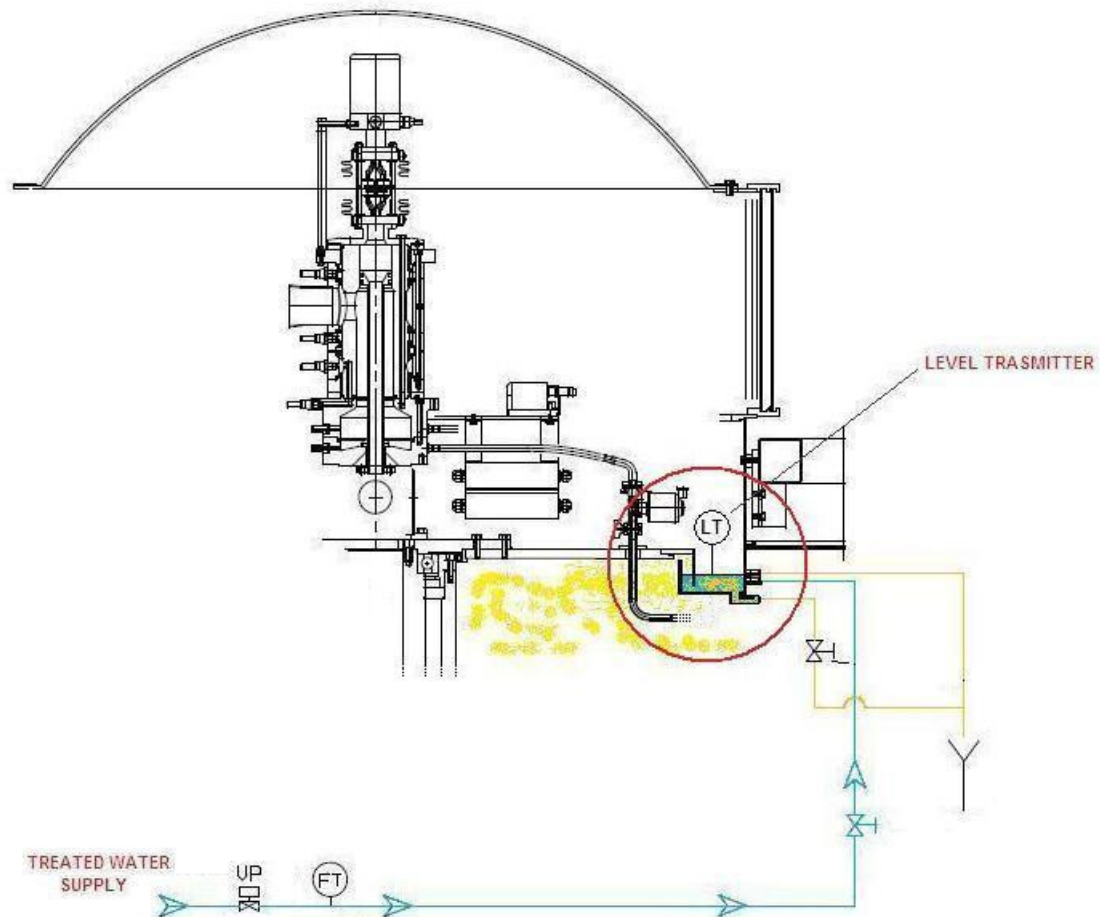

Dear Customer,

Gea Procomac would like to take this opportunity of informing that there is a possibility of modifying the seal which isolates the environment of the bottle sterilizer from the outside. The upgrade consists in replacing the retaining seal with a water barrier (**hydraulic retainer**) which prevents the outflow of peracetic steam from the sterilizer.

The hydraulic retaining which GEA Procomac installs on the lines of the latest generation, can be applied on the sterilizers in your possession by means of installing an appropriate channel on the machine's carousel (the fixed part) and a carter on the rotating part. This channel is powered by treated water through a special hydraulic circuit. The automatic handling of the powered circuit assures a constant level in the hydraulic retainer in addition to a constant drain which allows a steady water replacement in the channel (to avoid an excessive residual of peracetic in the water).

ADVANTAGES IN THE NEW HYDRAULIC RETAINER

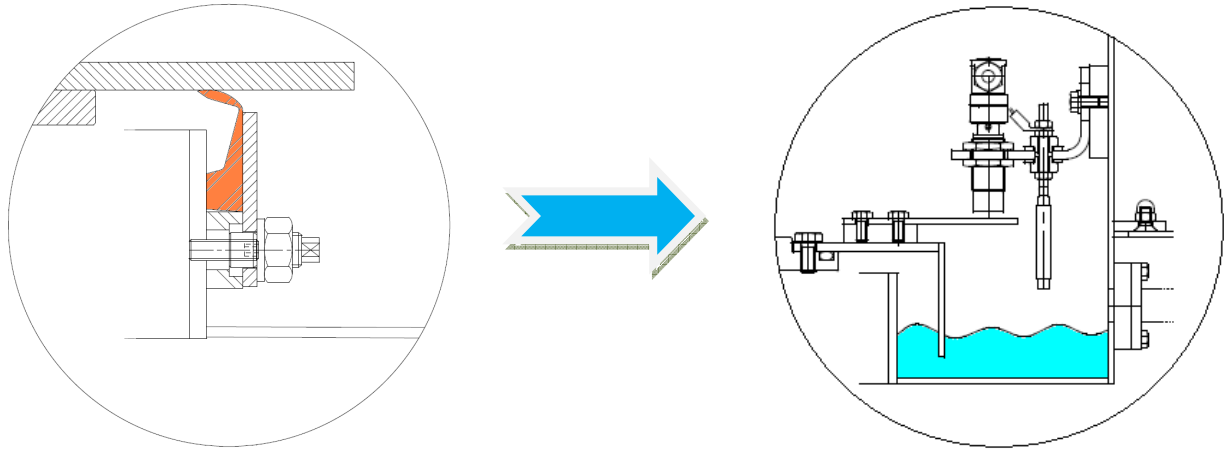

Applying the hydraulic retainer upgrade you will obtain the following advantages :

No wear and tear part : the new hydraulic retainer is practically exempt from all maintenance, unlike the current Universal-flex seal which needs to be periodically checked (every 4-6 months) and replaced on an average every 12 months of work.

Perfect insulation between the sterilizer's environment and the outside : the new hydraulic retainer has been designed by GEA Procomac in order to obtain a perfect internal / external isolation which is not always guaranteed with the old system. The lack of residual of peracetic steam towards the outsides means:

- **no exhalation of peracetic in the environment surrounding the sterilizer**
- **safeguard of the electro-pneumatic components present in the upper part of the sterilizer's carousel**

Elimination of the rubbing parts : the upgrade of the hydraulic retainer means the removal of all the parts which rub together between the rotating carousel and fixed part. The current Universal-flex seal with usage, tends to dry up thus increasing the friction of the carousel and therefore causing abnormal vibrations on the entire bloc.



SUPPLY CONDITIONS

For all relevant supply conditions, we kindly ask you to contact our Upgrades Dept, who will be pleased to formulate the best technical / commercial proposal for the hydraulic retainer upgrade relevant to the GEA Procomac Spa Aseptic line sterilizers in your possession.

GEA Procomac S.p.A.
Via Fedolfi 29
43038 Sala Baganza (PR) Italy
Tel + 39 0521 839411
Fax +39 0521 839572
ESP.procomac.it@geagroup.com
www.procomac.it