

UPGRADE OUTLET FILTRATION FOR UNIDOX (INSERTION SECOND FILTER IN PARALLEL)



Dear Customer,

Gea Procomac Spa communicates the opportunities to install on the unit for production of the sterilizing solution based on peracetic acid (Unidox) present in the aseptic plant that you have, a second filtration group on the outlet of the solution.

The new filtration group in the outlet will be installed in parallel with the one presently installed, by thus allowing the **production to continue** when the first filter will be jammed. Through the differential pressure control, when the value of the prefixed set value will be reached (it can be set from the operating panel) the filter exchange from the “filter working” to the “filter waiting” will happen automatically without interrupting the oxonia feeding to the plant.

After the filters exchange, it will be possible to remove the jammed filter and proceed with the clearing of the same one, so as to make it available for the following exchange. Fitting controls of the filters on the machine will allow to perform these operations with the machine in function in conditions of absolute safety.

Actual Configuration (One filter in the outlet)

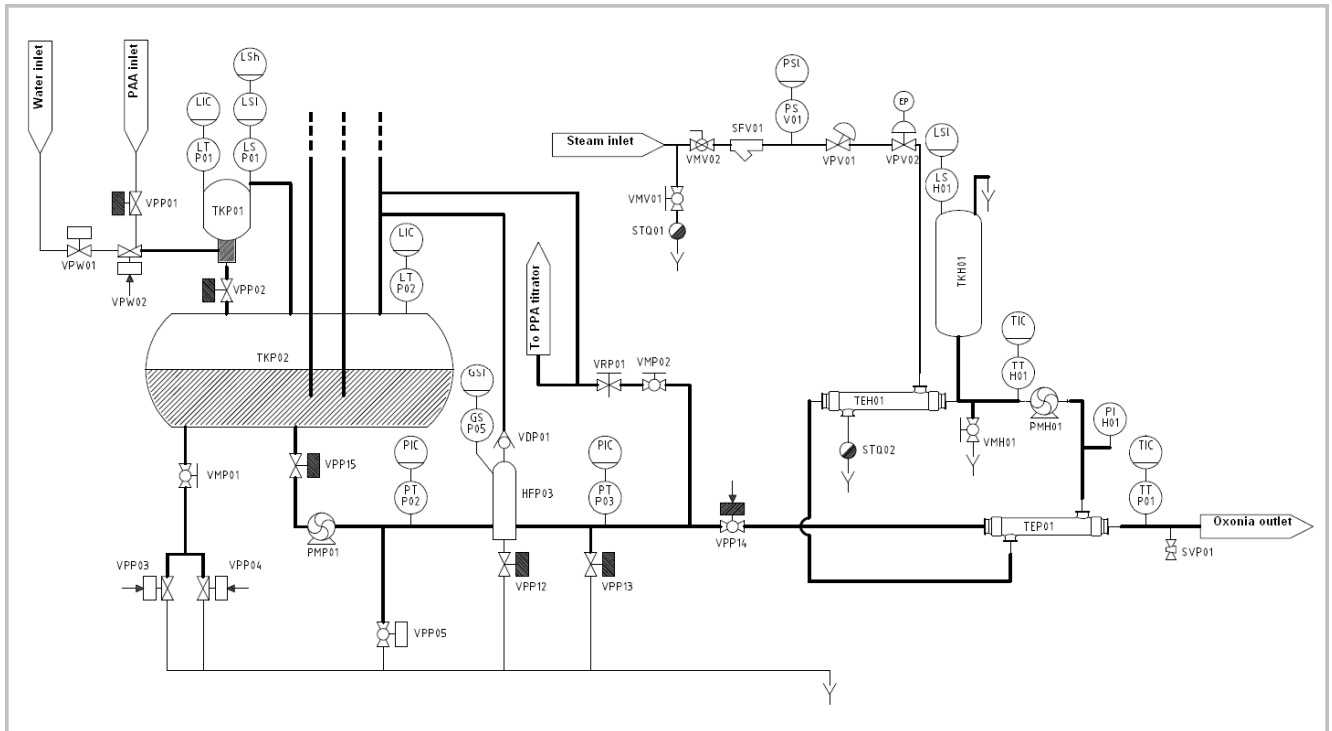

Future Configuration (Two filters in the outlet)

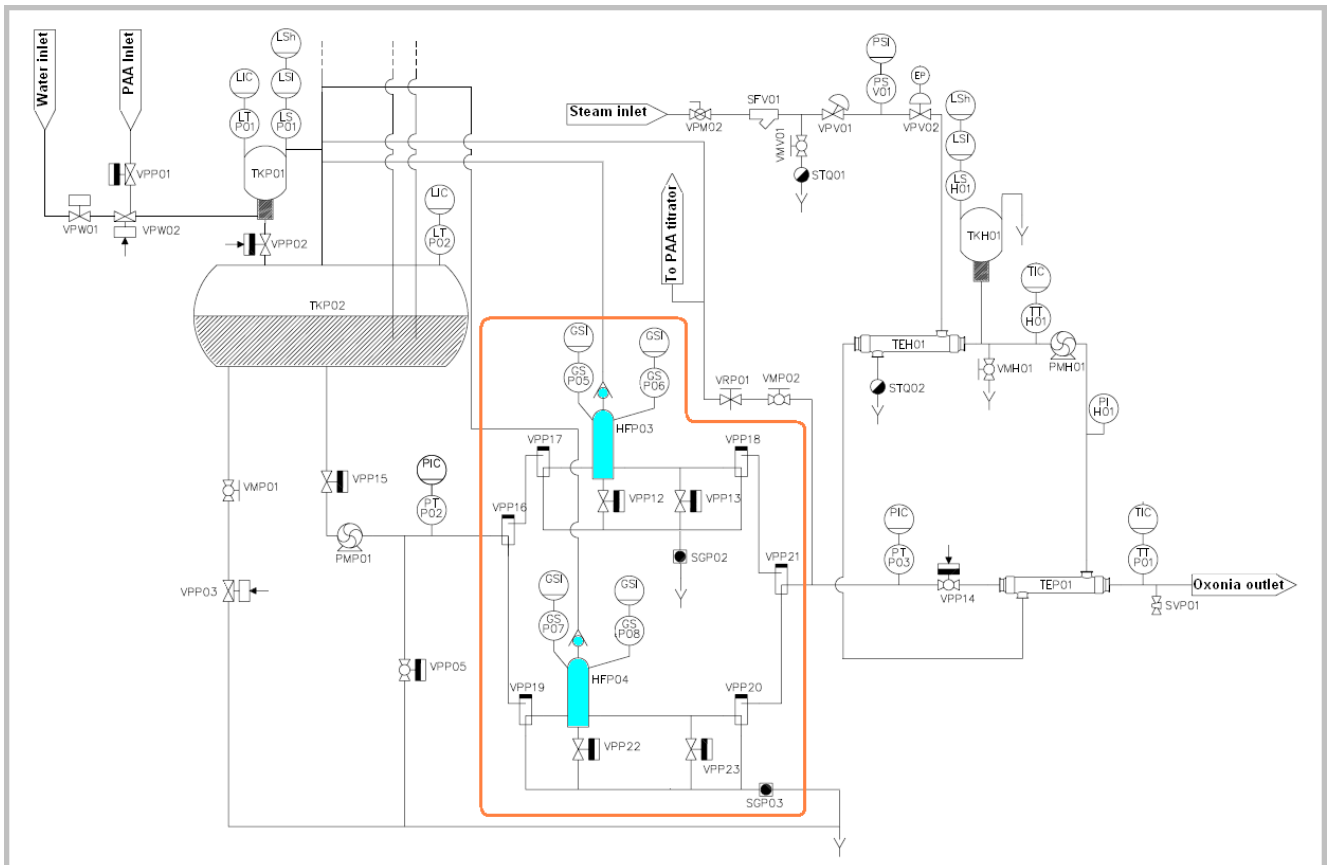



Supply Conditions

Concerning the supply conditions, we ask you please to turn to our Upgrade Dept., they will prepare for you the best technical/commercial offer for the installation of the second filter in the outlet in the Unidox Gea Procomac Spa that you possess.

GEA Procomac S.p.A.
Via Fedolfi 29
43038 Sala Baganza (PR) Italy
Tel + 39 0521 839411
Fax +39 0521 839572
ESP.procomac.it@geagroup.com
www.procomac.it